



FAUTEUIL DE PRÉLÈVEMENT
BLOOD SAMPLING CHAIR

Deneo®.Lab



Version : 10-2010



CONFORT COMFORT

- Rotation 360° (sur certains modèles)
- Encombrement réduit, optimisation de l'espace
- Sellerie **Bodyshape®** : positionnement naturel
- 360° rotation (on specific models only)
- Reduced volume, optimized space
- **Bodyshape®** upholstery: natural body position

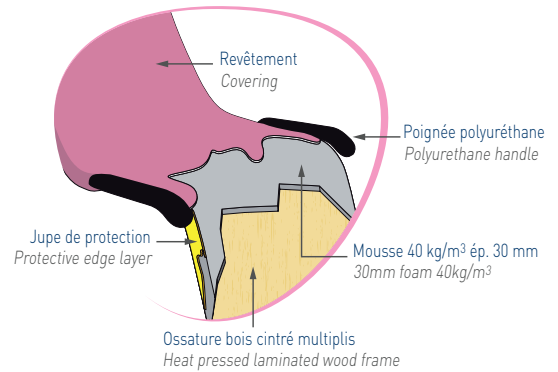

HYGIÈNE HYGIENE

- Nettoyage facilité
- Sellerie sans couture
- Poignées amovibles
- Easy to clean
- Seamless upholstery
- Removable handles

SÉCURITÉ SAFETY

- Position d'urgence facilitée, sans effort et rapide
- Appui-bras sur le dossier et poignées intégrées → longévité
- Base circulaire : stabilité du fauteuil
- Capacité patient : 200 kg
- Easy, effortless and rapid emergency position
- Armrests on the backrest and integrated handles → long service life
- Circular base: chair stability
- Maximum capacity: 200 kg

Design : Alain Duteil

ACCESSIBILITÉ ACCESSIBILITY

- Concept **Sit'n Go®** : position d'accueil à 50 cm du sol
- **Sit'n Go®** concept: welcome position at 50 cm from the ground

Concept **Sit'n Go®** / **Sit'n Go®** concept

Position initiale du fauteuil. Initial chair position.



Le patient s'appuie sur les 2 poignées latérales et le fauteuil se met en position d'accueil. The patient positions his hands on the lateral grips and the seat lowers to facilitate the entry.



Le fauteuil reprend sa position sans aucune intervention du praticien. When the patient leans back, the chair automatically swings back to a comfortable position.



La **position d'urgence** peut être obtenue à n'importe quel moment tout en maintenant la position des bras par rapport au corps. Effortless, the **emergency position** is obtained at any time, without effort for the practitioner.

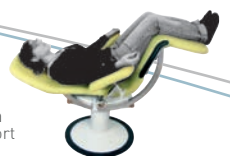

CARACTÉRISTIQUES STANDARD

Hauteur fixe (assise 50 cm)
et hauteur variable hydraulique (assise réglable de 51 à 71 cm)
Structure et base circulaire en acier finition époxy gris nuage
(sauf réf. 80010-01F et 80010-01R)
2 poignées polyuréthane intégrées au niveau de l'assise
Sellerie monobloc sans couture, revêtement M1
mousse épaisseur 30 mm, densité 40 kg/m³
2 appui-bras amovibles, incurvés sur rotules
avec mousse et revêtement M1 thermoformé sans couture
Système Sit'n Go®
Poids maximum du patient autorisé 200 kg
(testé en statique à 500 kg)

STANDARD FEATURES

Fixed height (seat at 50 cm)
and hydraulic variable seating height from 51 to 71 cm
Light grey epoxy covered steel for the base and structure
(except ref. 80010-01F and 80010-01R)
Two lateral polyurethane hand grips integrated to the seat
One-piece structure seamless upholstery
foam thickness 30 mm, density 40 kg/m³
Two removable formed armrests. Swivel adjusting system.
Seamless heat formed M1 covering
Sit'n Go® system
200 kg patient weight capacity
(tested at a static weight of 500 kg)



Modèles Models	Hauteur fixe base circulaire Fixed height circular base		Hauteur fixe base 4 roues ø 50 mm Fixed height base 4 castors ø 50 mm		Hauteur variable hydraulique Hydraulic variable height		Avec rotation With rotation	
80000-01F	●							
80000-01R	●						●	
80010-01F			●					
80010-01R			●				●	
80070-01R					●			●

Optimiser l'espace Optimize space

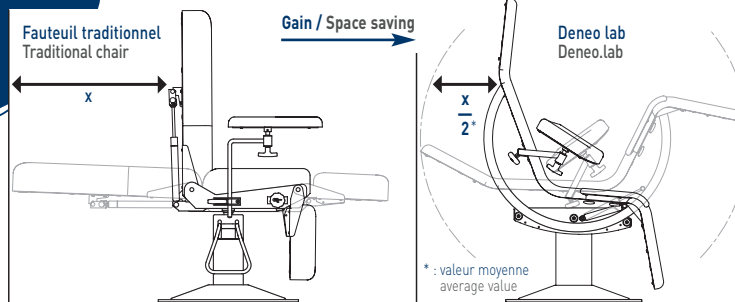

La rotation 360° permet
au praticien de prélever
sur l'un ou l'autre bras
sans se déplacer.

The 360° rotation
allows easy
transition to
the opposite
side of the
patient without
moving.



Accessoires Accessories



Porte-rouleau
(long. maxi 50 cm, ø 20 cm)
Paper roll holder
(length max 50 cm, ø 20 cm)



Plateau seul
Stainless steel pan
(240 x 180 x 30 mm)

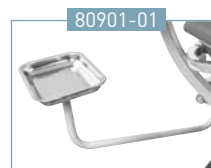

Plateau avec bras rigide
pivotant (droite / gauche)
S/S pan with swivelling arm
(right / left)



Plateau avec bras flexible
pivotant (droite / gauche)
S/S pan with flexible
swivelling arm (right / left)



Protection plastique
(côté jambes)
Plastic covering (leg
section)



Support pour étaux
(côté jambes ou tête)
Clamp support
(leg or head side)



Étau pour accessoires
ø 16 mm
Clamp for accessories
ø 16 mm



Protection plastique
(côté tête)
Plastic covering
(head section)



Se référer à la
documentation
Refer to the literature



Tige porte-sérum
autobloquant 2 crochets
Auto-locking 2 hook IV pole

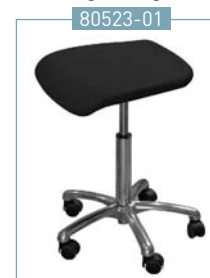

Tabouret
Stool
hauteur/height
mini : 47 cm / maxi : 66 cm



Pouffe
Pouffe
hauteur/height
52 cm

Choix de selleries non-feu M1
Choice of M1 fire retardant upholstery

Basic

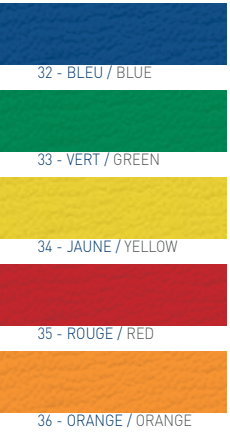

Trendy



Classic



96 - ÉTAIN / TIN

Noirs



Non classé M1 / Not classified M1

Selleries RITTER
RITTER upholstery
Non classé M1.
Not classified M1.

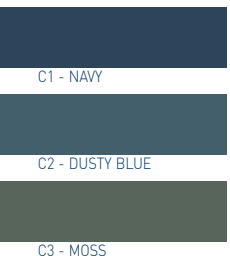

Hauteur fixe / Fixed height

Hauteur fixe
Fixed height

Poids net
Net weight
53 kg

Poids brut
Gross weight
67 kg

Volume 1,164 m³

Hauteur variable
hydraulique
Hydraulic
variable height

Poids net
Net weight
60 kg

Poids brut
Gross weight
74 kg

Volume 1,164 m³

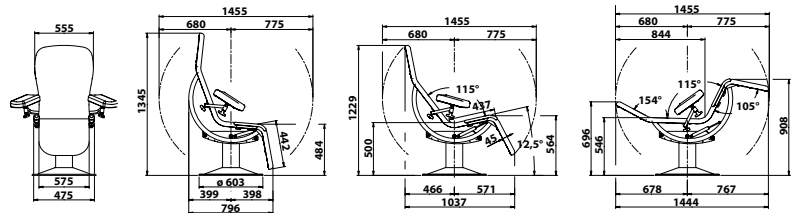

Hauteur variable hydraulique / Hydraulic variable height

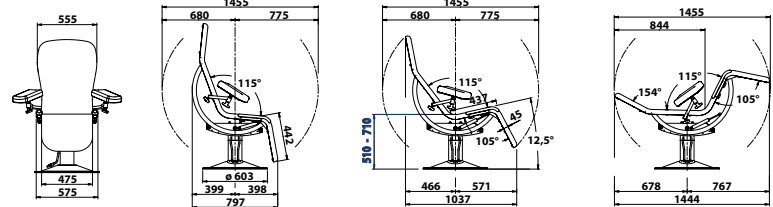

Hauteur fixe sur base 4 roues / Fixed height with 4 castors base

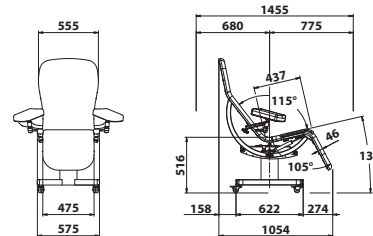

F005/FE-50/10

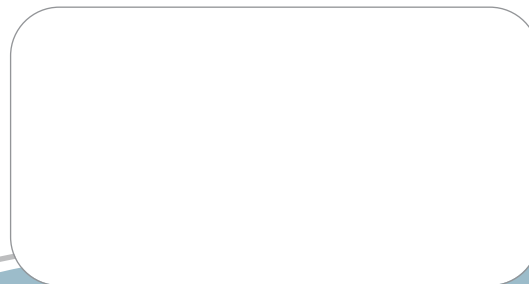

Midmark Europe SAS
22, rue de Saint-Denis - 53500 Ernée
www.promotal.com

